

2000 VW Passat Cluster Removal Instructions

Instrument Cluster, Removing And Installing

CAUTION!

Before beginning repairs on the electrical system:

- Obtain the anti-theft radio security code.
- Switch the ignition off.
- Disconnect the battery Ground (GND) strap.
- After reconnecting battery, re-code and check operation of anti-theft radio.

CAUTION!

Special safety precautions apply to vehicles equipped with airbags.

Special tools, testers and auxiliary items needed

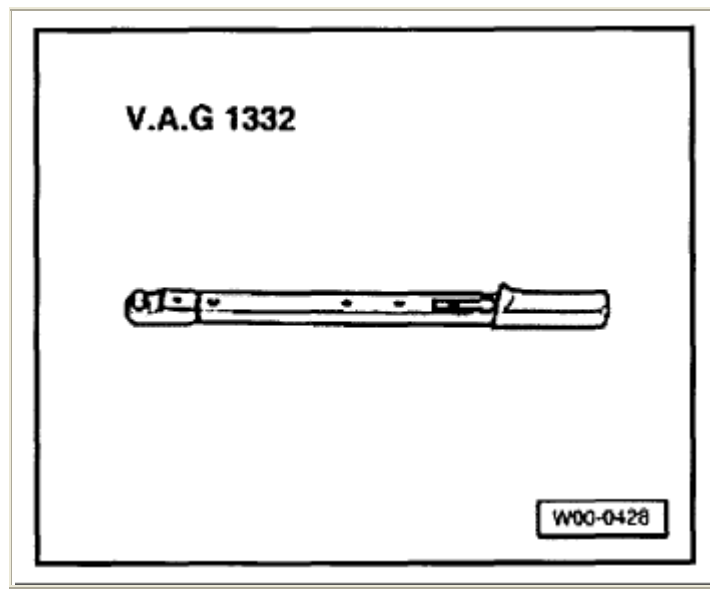

- VAG 1332 Torque wrench (or equivalent 40 - 200 Nm)

2000 VW Passat Cluster Removal Instructions

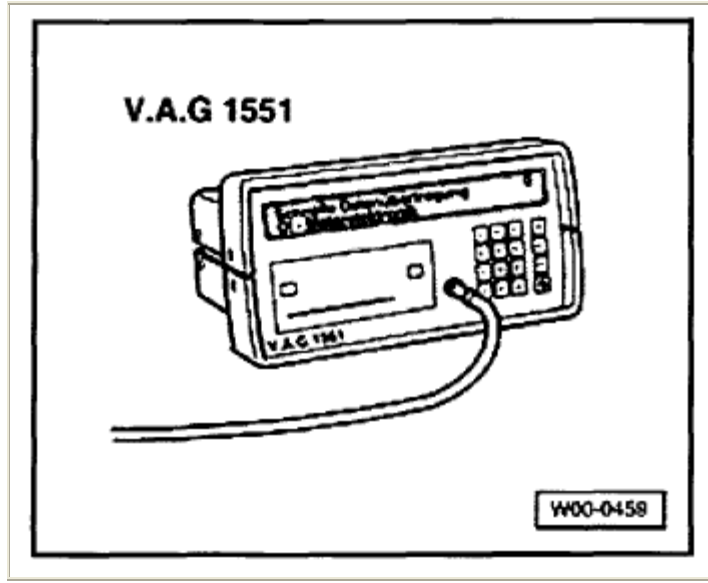

- VAG 1551 Scan Tool (ST)
- Optional: VAG 1552 or VAS 5051 Diagnostic Testing and Information System

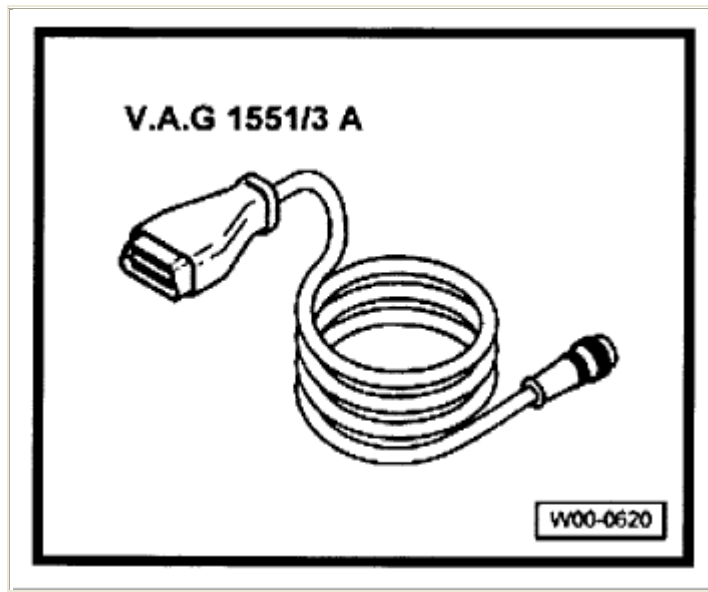

- VAG 1551/3A, or VAG 1551/3B Adapter cable

2000 VW Passat Cluster Removal Instructions

Removing

If replacing a malfunctioning instrument cluster with a new one, note [odometer](#) reading on existing cluster prior to removal.

- Remove driver's airbag.

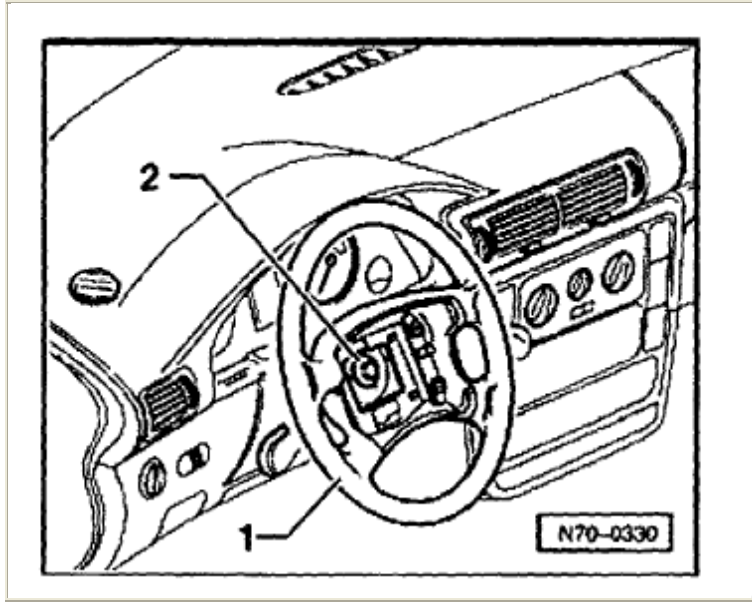

- Remove hex bolt -2- (always replace). Tightening torque: 60 Nm (44 ft lb) .
- Position steering wheel -1- in central position (wheels straight ahead).
- Pull steering wheel -1- from steering column.

2000 VW Passat Cluster Removal Instructions

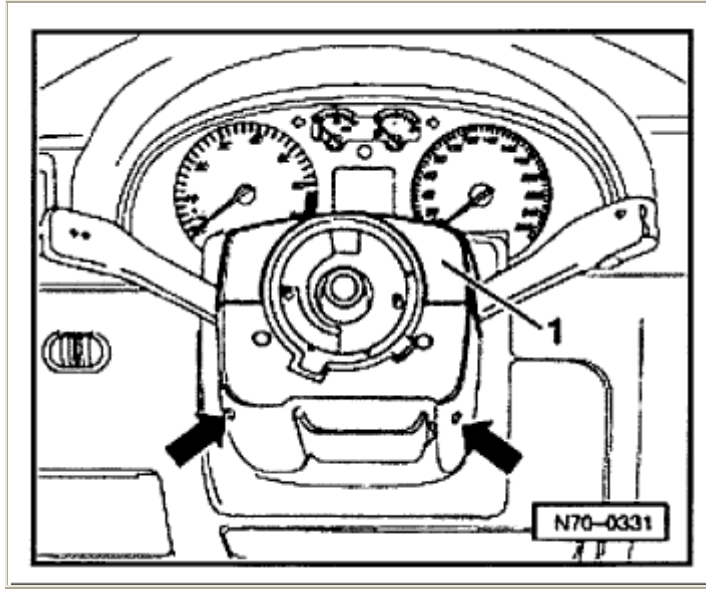

- Remove both (Phillips head) screws -arrows-
- Remove upper steering column trim -1- upwards.

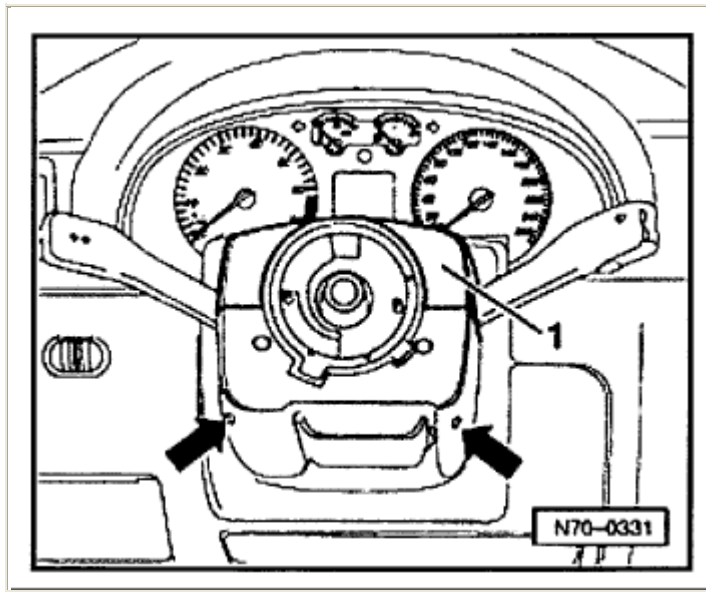

- Remove four (Phillips head) screws -arrows-.
- Remove socket head bolt -1-.

2000 VW Passat Cluster Removal Instructions

- Release steering wheel height adjustment -2-.
- Remove lower steering column trim -3- downwards.

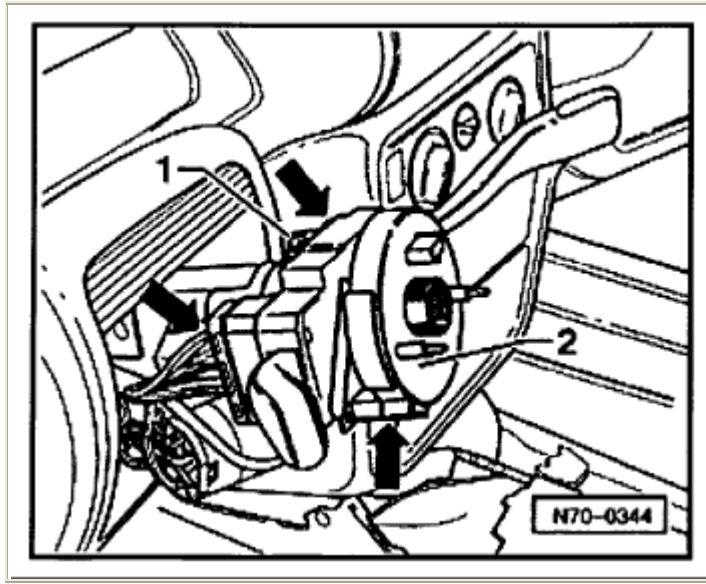

- Loosen socket head bolt -1-.
- Disconnect electrical connectors -arrows- from steering column switches.
- Remove steering column switches

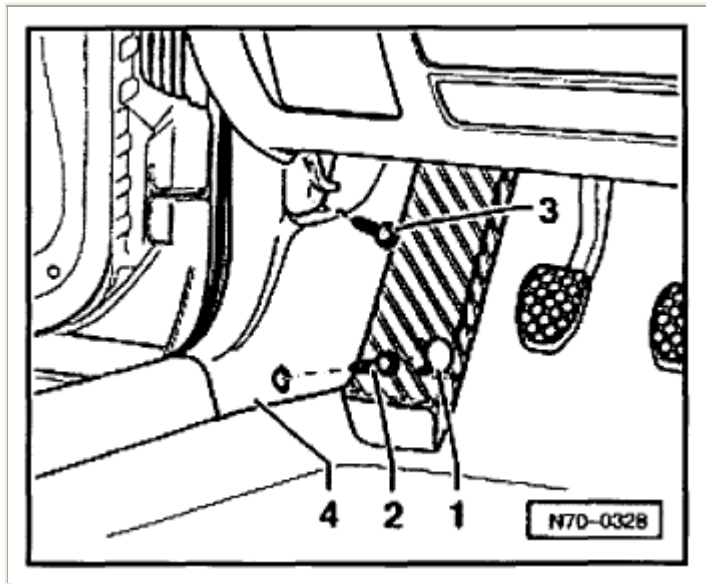

2000 VW Passat Cluster Removal Instructions

- Pry off cap -1-.
- Remove screws -2- and -3-.
- Unclip kick panel trim -4- from driver's side sill trim strip and remove.

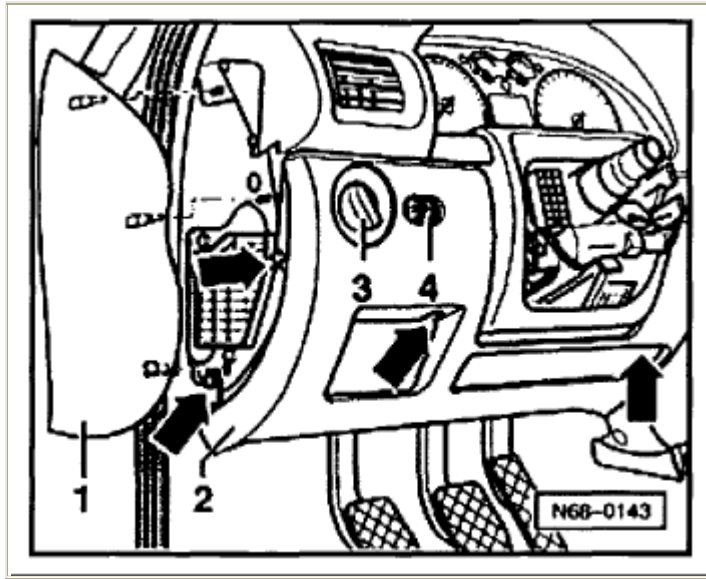

- Unclip cover -1-.
- Remove screws -arrows-.
- Remove lower instrument panel trim, left -2-.
- Disconnect electrical connectors from light switch -3- and headlight range adjustment -4- (where applicable).

2000 VW Passat Cluster Removal Instructions

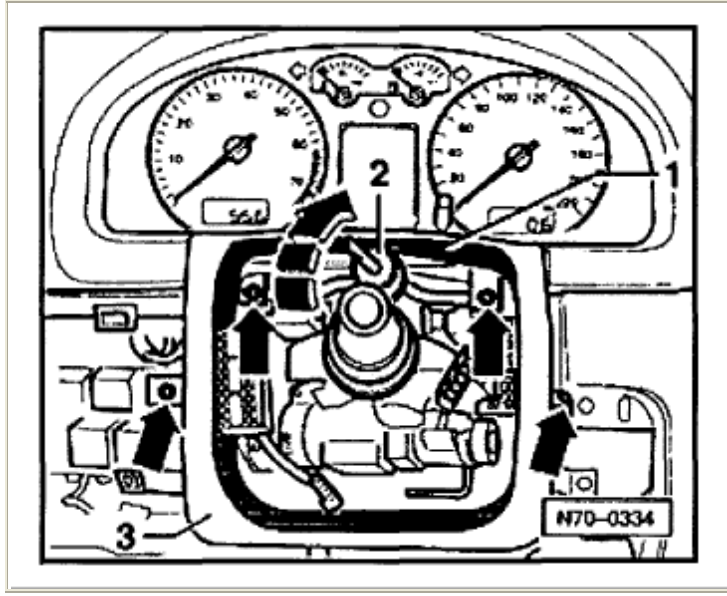

- Slide trim -1- upwards and hold in place by wedging screwdriver handle -2-.
- Remove four screws -arrows-.
- Remove cover -3-.

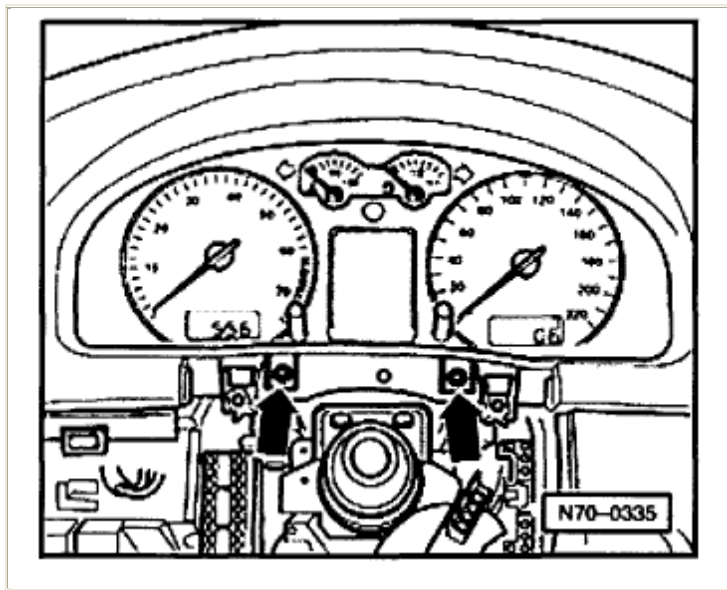

2000 VW Passat Cluster Removal Instructions

- **Remove two screws -arrows-.**
- **Pull out instrument cluster from opening.**
- **Disconnect electrical connections on rear of instrument cluster and remove cluster from instrument panel.**

Installing

- **Install in reverse order of removal.**
- **Perform functional check of instrument cluster.**

If replacing a malfunctioning instrument cluster, and a function check shows no further malfunctions, proceed as follows:

- **Code instrument cluster**
- **On instrument clusters from 08.99, the Data Bus On Board Diagnostic Interface -J533- must also be coded according to vehicle market version and equipment level variables.**
- **Adapt [odometer](#) reading.**
- **Where applicable, adapt instrument cluster for Service Reminder Indicator (SRI) functions.**
- **Where applicable, adapt instrument cluster for anti-theft immobilizer functions.**